

**Serial Interface:**

Supported Protocols: RS-232, RS-485  
# of Ports: 1 RJ45

*Serial Communication Parameters:*  
9600 Baud  
8 Data bits  
1 Stop Bit  
No parity

*RJ45 Pinout*  
Pin 1,2: RS-485  
Pin 3: Transmit (TX)  
Pin 4,5: DC+  
Pin 6: Receive (RX)  
Pin 7,8: DC- (Ground for RS-232)

Pins 1&2, 4&5, 7&8 internally connected

**Power Requirements:**

Input Power: 9VDC, 200mA - UL Approved  
Power Consumption: 20mA

**Mechanical:**  
Casing: Poly Case  
Dimensions: 3" L x 4" W x 1.75" H

**Radio Frequency:**  
Range: 75 feet\*  
FCC Approved  
\* Under optimal conditions (Some sort of disclaimer)

**Infrared Capability\*\*:**  
Compatible with Somfy's 24 channel IR transmitter

\*\* Optional IR sensor required

### DESCRIPTION



The addressable Universal RTS Interface II (URTSI II) can be used to communicate between home automation or other third party systems and RTS Motors and controls. It is capable of individual or group control, and can be operated via infrared remote, RS232 and RS485 serial communication. Once an input is activated, an RTS radio command is sent to the automated window treatment.

**Part #13454**

### CONNECTION DIAGRAM

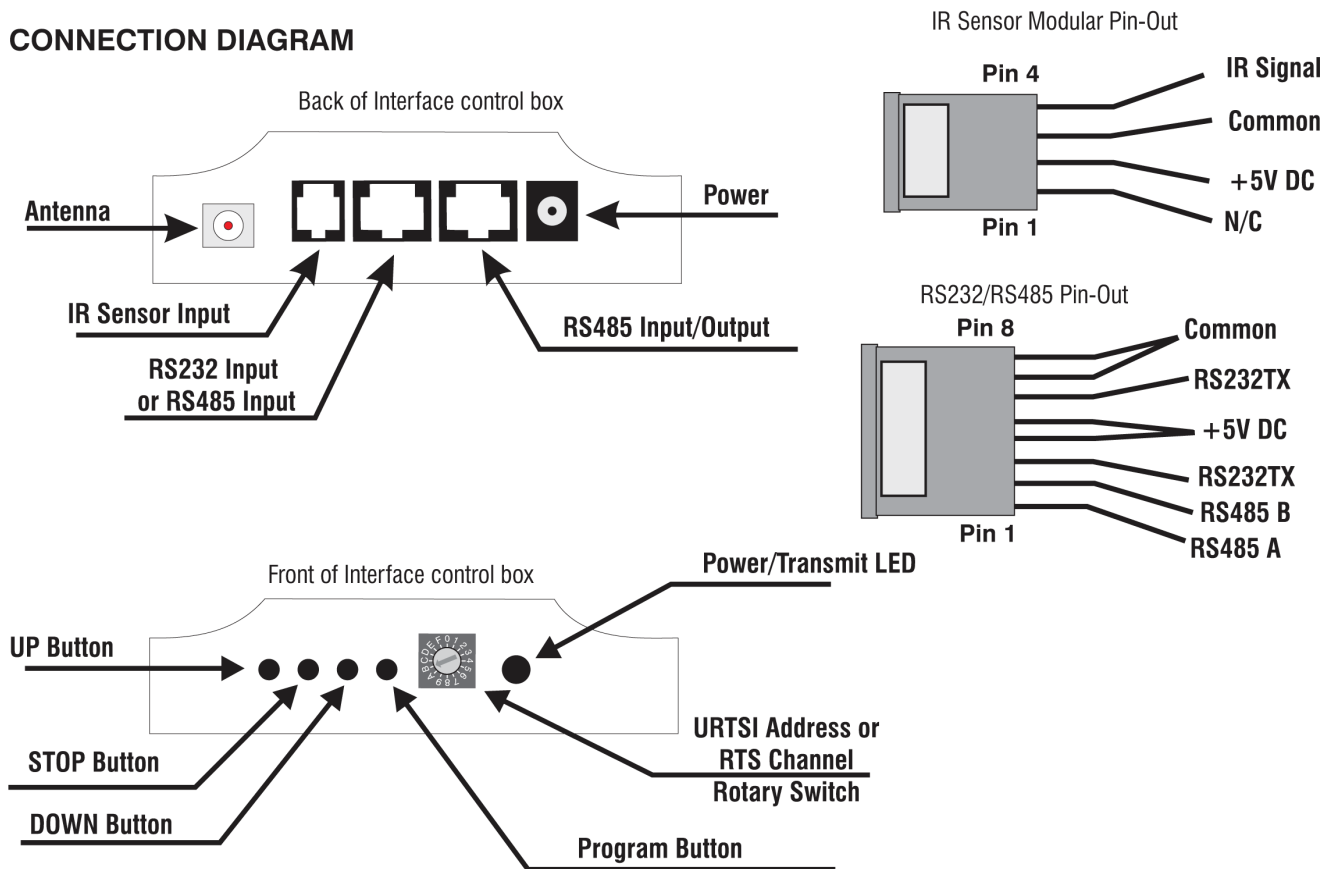

### FCC INFORMATION

This device complies with Part 15 of the FCC Results. Operation is subject to the following two conditions:

1. This device may not cause harmful interference, and
2. This device must accept any interference received, including that which may cause undesired operation.

NOTE: This equipment has been tested and found to comply with the limits for CLASS B digital device, pursuant to Part 15 of FCC Rules.

These limits are designed to provide reasonable protection against harmful interference when the equipment is operated in a commercial environment. This equipment generates, uses and can radiate radio frequency energy and, if not installed and used in accordance with the instructions, may cause harmful interference to radio communications. However, there is no guarantee that interference will not occur in a particular installation. If this equipment does cause harmful interference to radio or television reception, which can be determined by turning the equipment off and on, the user is encouraged to try to correct the interference by one or more of the following measures:

1. Reorient or relocate the receiving antenna
2. Increase the separation between the equipment and receiver
3. Connect the equipment into an outlet on a circuit different from that to which receiver is connected
4. Consult the dealer or experienced radio/TV technician for help.

### WARNING

Changes or modifications not expressly approved by the manufacturer could void the user's authority to operate the equipment.

## A. INITIAL SETUP

1. Connect a 9v DC transformer (included) to the receptacle on the back of the control box. The LED will light green to indicate power.
2. Be careful not to mount or enclose Interface on or in metal, as this may effect radio reception.
3. Set the RTS Receiver or motor into its Programming Mode. Refer to the installation instructions of the relevant RTS receiver or motor for this procedure.  
NOTE: For initial programming provide power only to the motor or control being programmed.
4. Using the rotary switch, select the channel to be programmed. Letters A through F stand for channels 10 through 15, 0 for 16. Briefly press the programming button (1 sec. max), the window treatment will jog to indicate the channel has been memorized.
5. Repeat the steps above for each channel or product to be memorized, up to 16.
6. To test the control operation, simply press the UP, STOP or DOWN buttons on the front of the control. The window treatment should move appropriately. The LED will flash red to indicate the radio signal has been transmitted.

## B. INFRARED OPERATION

1. The RTS Interface is compatible with Somfy's multichannel transmitter. Connect an infrared sensor to the appropriate connector on the back of the Interface.
2. Each individual motor is activated by first aiming the transmitter at the sensor and pressing the desired unit number on the transmitter and then pressing the UP or DOWN buttons. Press the center button to STOP the window treatment at any time.

## C. RS232 OPERATION

1. The Somfy RS232 interface uses the following communications settings: **9600 Baud, 8 Data Bits, 1 Stop Bit, No Parity**
2. Set the rotary switch to position 1.
3. The basic format for communication is as follows: **URTSI ADDR MOTOR CHAN DIR**  
The URTSI address is 01.  
The motor channel should be 2 digits from 01 to 16.  
The directional commands are: U = Up D = Down S = Stop
4. Examples:  
Motor 1 UP: 01 01 U  
Motor 5 DOWN: 01 05 D  
Motor 12 STOP: 01 12 S

## D. RS485 OPERATION

1. The Somfy RS485 interface uses the following communications settings: **9600 Baud, 8 Data Bits, 1 Stop Bit, No Parity**
2. With RS485, it is possible to connect 16 Universal RTS Interfaces on one network. Each Interface will have its own address. To select the address, set the rotary switch to the desired number. Letters A through F stand for addresses 10 through 15, 0 for 16.
3. The basic format for communication is as follows: **URTSI ADDR MOTOR CHAN DIR**  
The URTSI address should be 2 digits from 01 to 16.  
The motor channel should be 2 digits from 01 to 16.  
The directional commands are: U = Up D = Down S = Stop
4. Examples:  
URTSI 1, Motor 1 UP: 01 01 U  
URTSI 3, Motor 12 DOWN: 03 12 D  
URTSI 14, Motor 9 STOP: 14 09 S  
URTSI 10, Motor 15 UP: 10 15 U

## URTS II Specification

### General

The URTSII is an addressable (16), 16 channel RTS (Somfy Radio Protocol) interface that can be triggered via RS232 or connected and activated over a half-duplex, RS485 digital network. RS232 and RS485 is switch selectable. The URTSII will allow front-end home automation and building management systems, with native RS485, to control 256 RTS motors individually. Local control of the URTSII is possible using IR.

### Electrical

1. URTSII is powered from either the CAT 5 (RS485) or external plug-in transformer. Damage can not occur if both supplies are connected or polarity is reversed.
2. RS232 bus: 3-wire: Tx, Rx, Common, EIA compliant
3. RS485 bus: 2-wire EIA compliant
4. Power: 12V (filtered but not regulated), GND
5. CAT 5 cable connected to a RJ45 connector is used for the RS485 bus (1 pair) and 2 pair for power. Pairs for power should be the unused Ethernet pairs.
6. RJ45 pin-out
  - 1 & 2, RS485
  - 4 & 5, DC+
  - 7 & 8, DC- (Common for RS232)
  - 3, Tx
  - 6, Rx
7. 20 ma maximum current draw
8. Transmitter must be designed in accordance with FCC part 15. Schematic shall be provided to increase transmitted power to European levels.
9. One Bi-Color LED:
  - Red: Flashes for 500 ms after RTS signal is sent
  - Green: Remains illuminated while unit is powered
10. Four Push Button Switches:
  - Programming Switch: used to bind one of the 16 RTS channels to RTS motors as described in FUNCTIONAL below
  - UP, DOWN and STOP Switches, used to send the appropriate RTS command as set by the rotary dip
11. Slide switch or equivalent to choose between RS232 and RS485.
12. 16-Position rotary DIP used to:
  - Choose one of 16 RTS channels to bind during programming
  - Set the unit code (1- 16) of the URTSII
13. External antenna, Articulating and connectorized. Link model HWR or equivalent.
14. IR Connector to connect optional IR sensor (ILT Version), requires 5 VDC, Signal, Ground, compatible with Somfy's 24 channel IR transmitter (Ch 1 –16 only)
15. Power Connector, 5.5 mm X 2.1 mm to accept external plug-in power supply (filtered but not regulated)
16. A maximum of 16 URTSII can be connected on one RS485 network segment

## URTS II Specification

17. A single dual serial chip device should be considered.

### Mechanical

18. PCB assembly to be mounted in Polycase enclosure AG-43 (<http://www.polycase.com/item/ag-43.html>)

19. \* Front face of the enclosure to be modified to accommodate LED, Programming switch, Directional switches, Rotary DIP, RJ45, Slide switch, power connector and antenna connector. Location to be agreed upon at a later date.

### Functional

20. Binding RTS

- With the motor receiver in programming mode, the rotary DIP is turned to a single channel 1 –16
- Once the preferred channel is selected, the program push-button is pressed for 1 second. The URTSII will then transmit the appropriate program command.

21. URTSII addressing: The URTSII unit address is set by selecting 1 – 16 on the rotary DIP. The dip must remain on the unit address during normal operation

### infrared

22. Each IR channel of the transmitter (1 –16) corresponds directly to the RTS channels 1 – 16. The commands are the same; UP/STOP/DOWN. The IR transmitter only activates the URTSII the IR receiver is connected to.

23. IR channels above 9 are a 2-button sequence. For example: channel 14 is 1, 4.

### Protocol

24. The command set is a ASCII as follows:

- <Unit><RTS Channel><Command>
- Unit = 01 – 16 address code
- RTS Channel = 01 – 16
- The command string is always 5 characters
- Command:
  - U = UP
  - S = STOP
  - D = DOWN
  - u = JOG UP
  - d = JOG DOWN

25. Data Rate: 9600 Baud, 1 Start Bit, 8 data bits, no parity, Stop bit

26. After receiving a command the URTSII should first execute the command and then echo the command. Only the URTSII that executed the command is allowed to echo it. The front-end unit manages collision avoidance. The URTSII is always a secondary device.

27. There is no priority command type (e.g. between IR, RS232 or RS485); the last command received is executed.