

# Skylight

**MOTORIZED SKYLIGHT SYSTEM**

SL3-ST-140-EM



Also available in:  
2 banded skylight system  
3 banded skylight system  
4 banded skylight system

# Skylight

**MOTORIZED SKYLIGHT SYSTEM** for inclined/sloped shades

Model: SL3-ST-140-EM

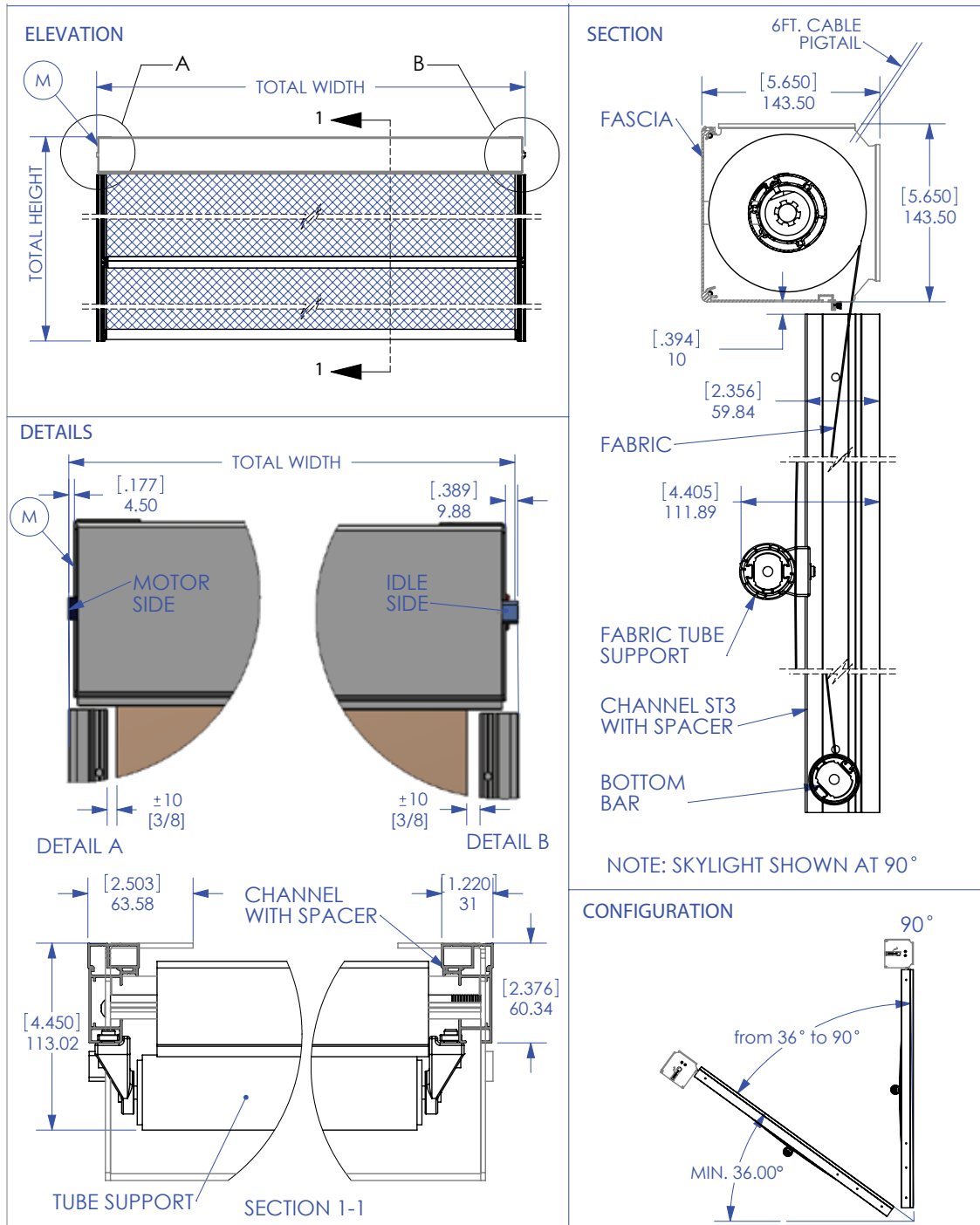

# Skylight

## MOTORIZED SKYLIGHT SYSTEM

Typical Application

Model: SL3-ST-140-EM

Application: Single side sloped

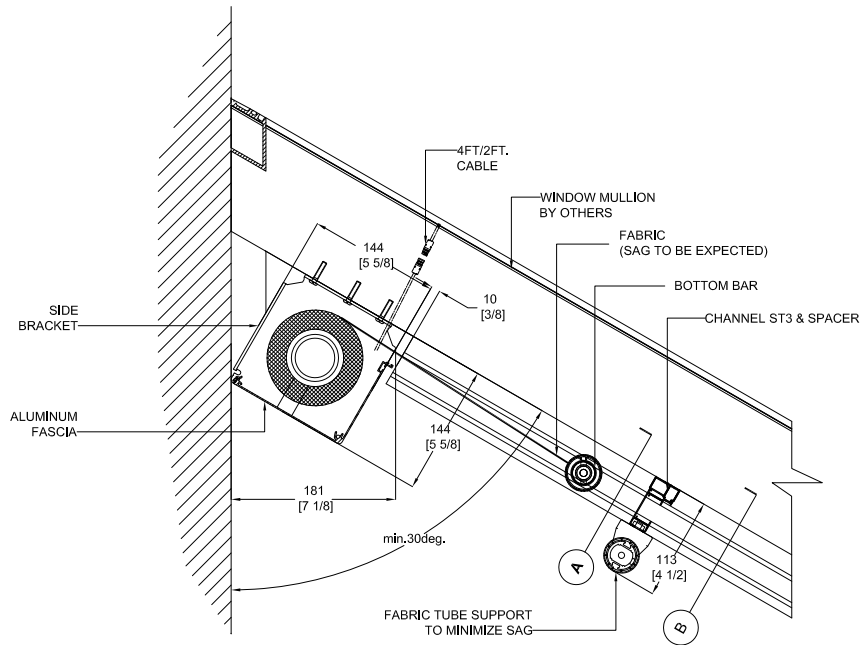

Model: SL3-ST-140-EM

Application: Double side sloped

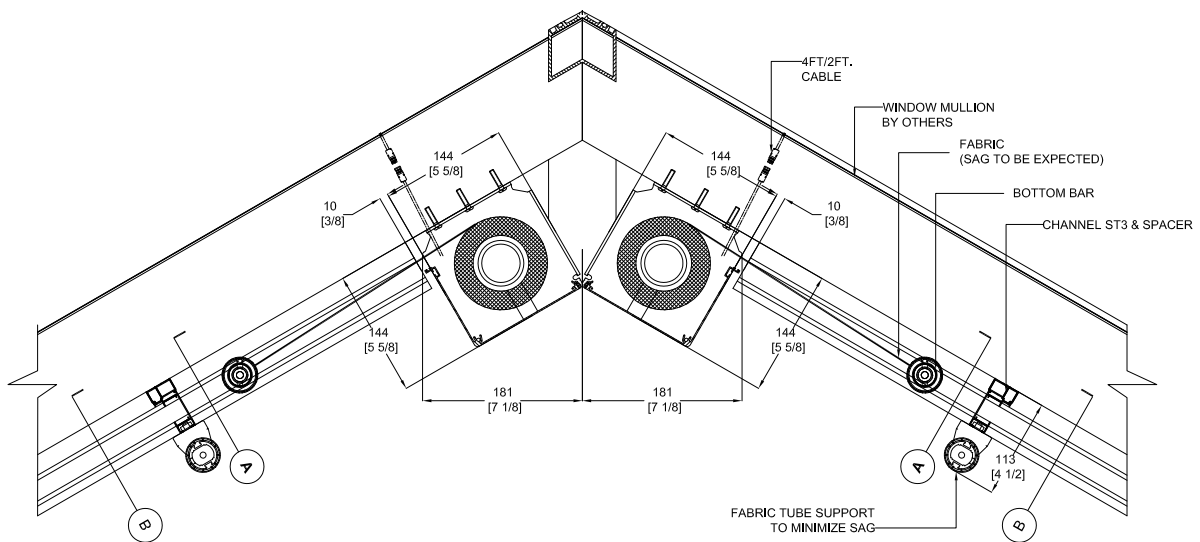

# Skylight

## MOTORIZED SKYLIGHT SYSTEM

Typical Application

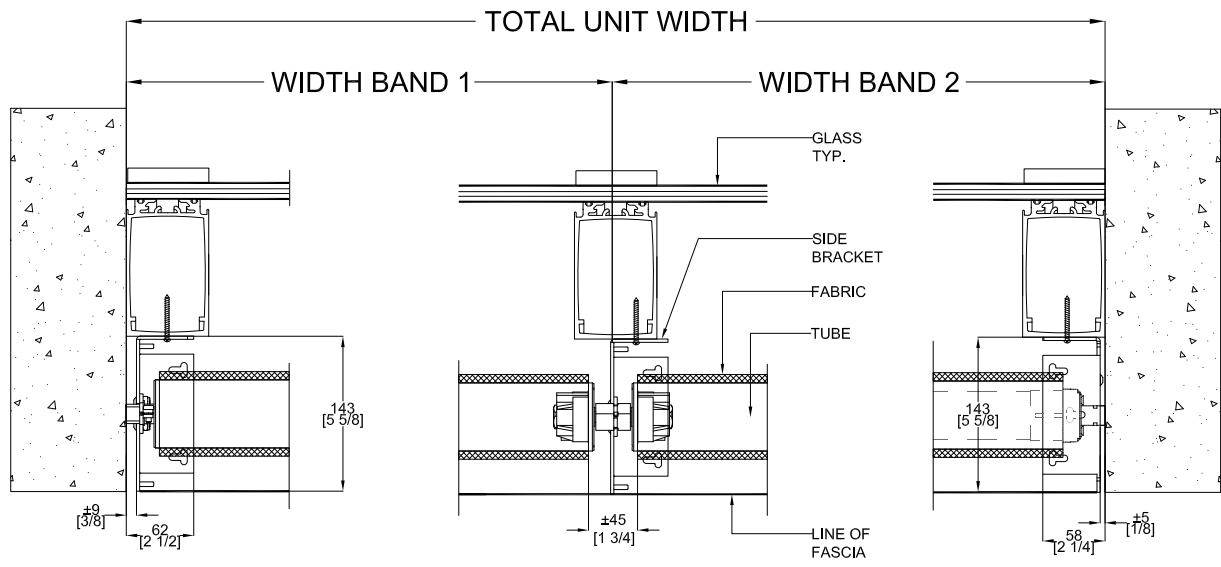

**A1** IDLE SIDE BRACKET  
TYPICAL INSTALLATION

**A2** INTERMEDIATE BRACKET  
TYPICAL INSTALLATION

**A3** MOTOR SIDE BRACKET  
TYPICAL INSTALLATION

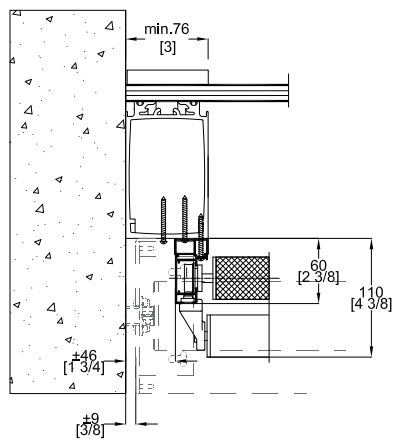

**B1** CHANNEL AND SUPPORT ROLLER  
TYPICAL INSTALLATION **IDLE SIDE**

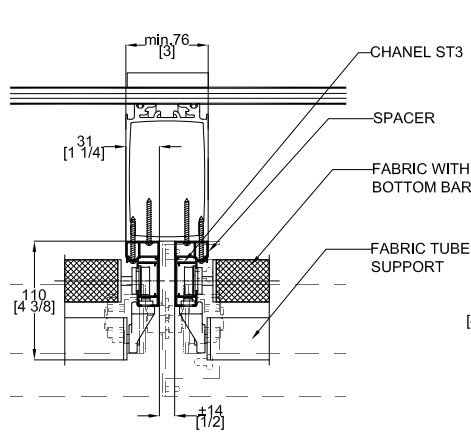

**B2** CHANNEL AND SUPPORT ROLLER  
TYPICAL INSTALLATION **CENTRE SIDE**

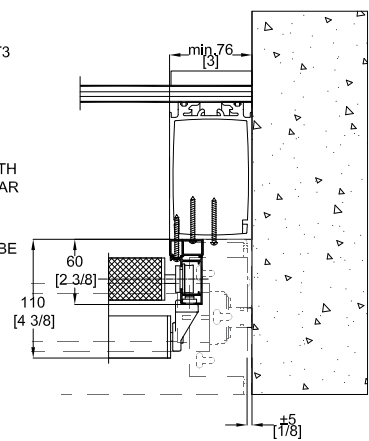

**B3** CHANNEL AND SUPPORT ROLLER  
TYPICAL INSTALLATION **MOTOR SIDE**

# Skylight

**MOTORIZED SL4**

Single Unit Skylight System



# Skylight

## MOTORIZED SL4

Single Unit Skylight System

