

Tekno

Lite-Lift® Operating System

SunProject Shading System Feature Lite-Lift® a smooth **state of the art easy lift** activated mechanism.

- **Lite-Lift®** provides a smooth constant effortless lift of medium to large shades with finger tip control.
- **Lite-Lift®** mechanism effortless lift alleviates stress on the chain and avoids chain breakage (Major cause of maintenance associated with chain operated shades).
- **Shade can be pulled down by the bottom bar** (without stripping or damaging the mechanism) without having to pull from the chain.
- **Shade mechanism cannot be stripped or damaged!**
- Virtually lasts forever. **Durable — Heavy use design**, important in commercial applications where products are in some cases abused.

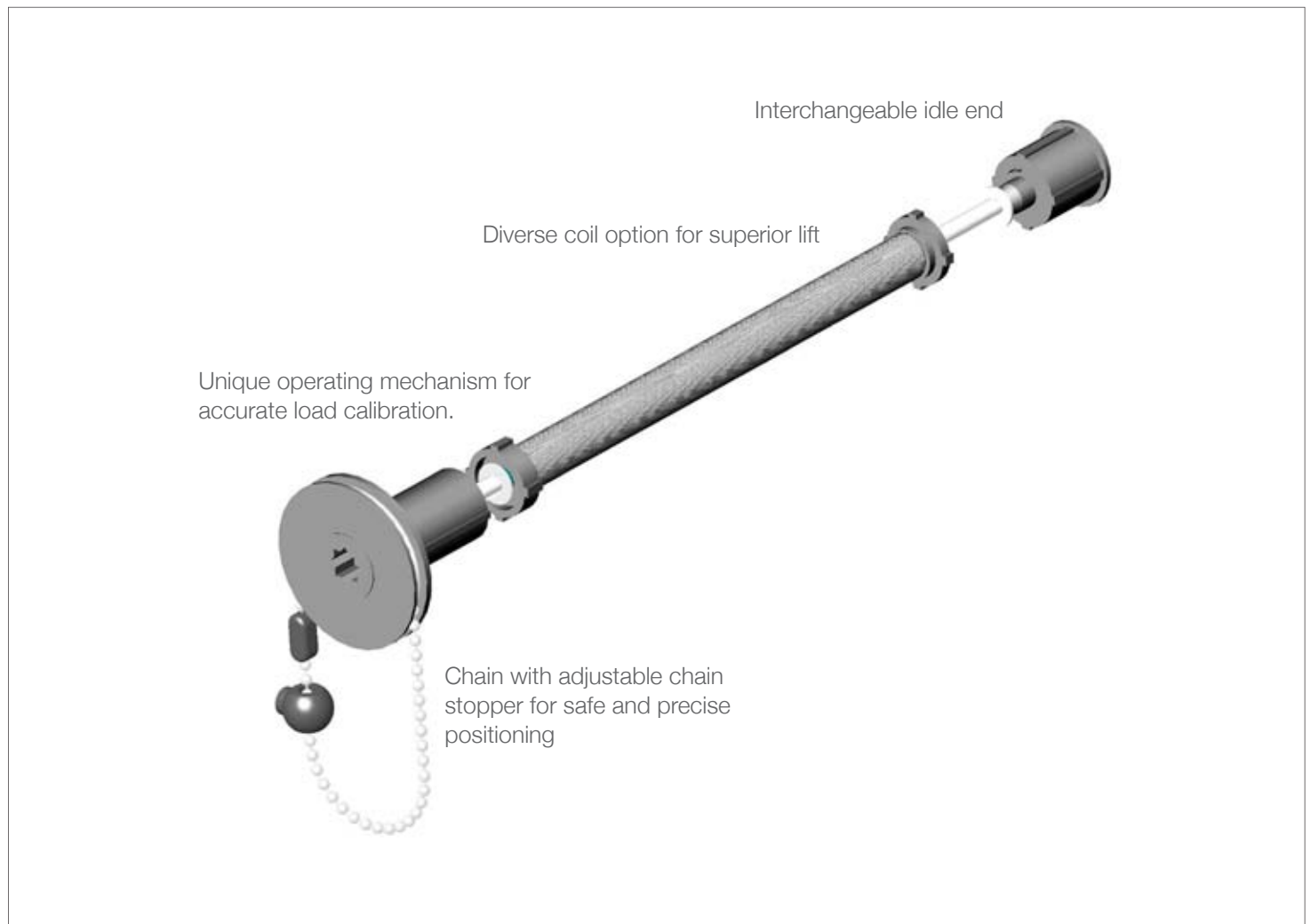

Tekno

Lite-Lift® Chain Operated Roller Systems

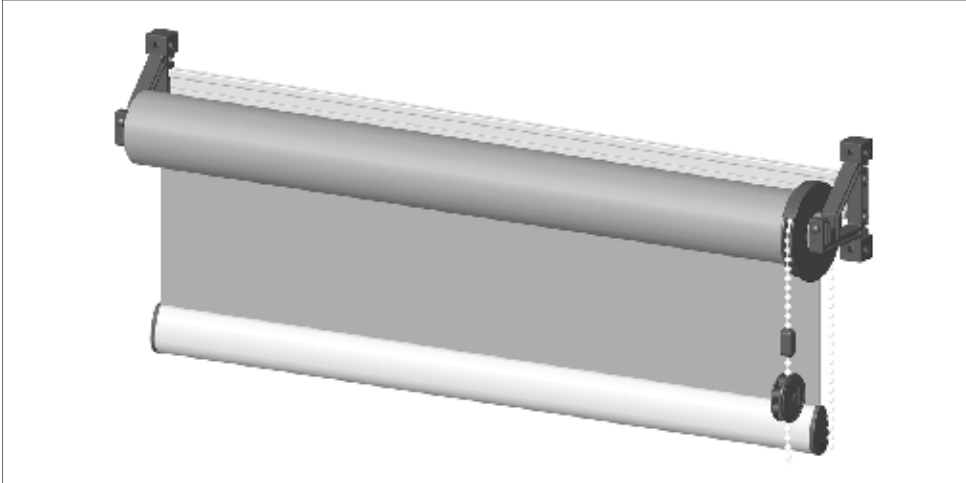

Tekno® Lite-Lift®
Open Roll TR
With Shade Holder

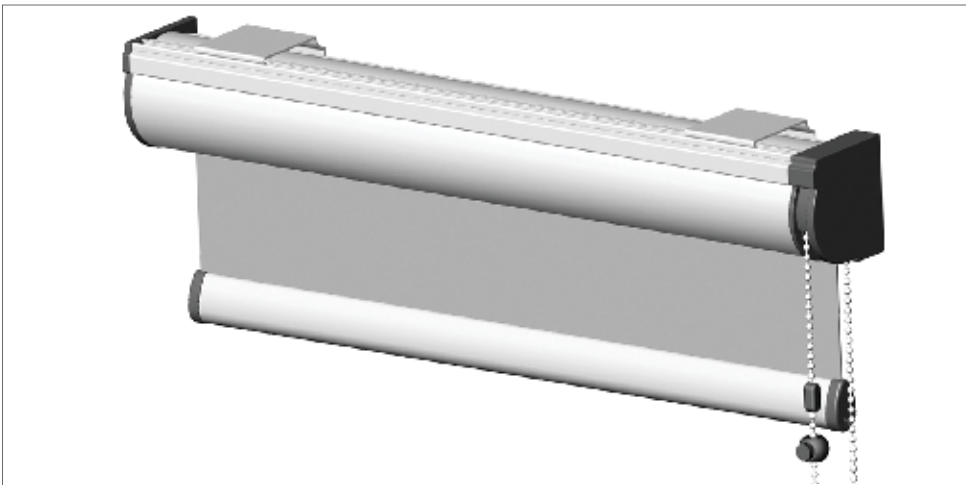

Tekno® Lite-Lift®
With Cassette 70

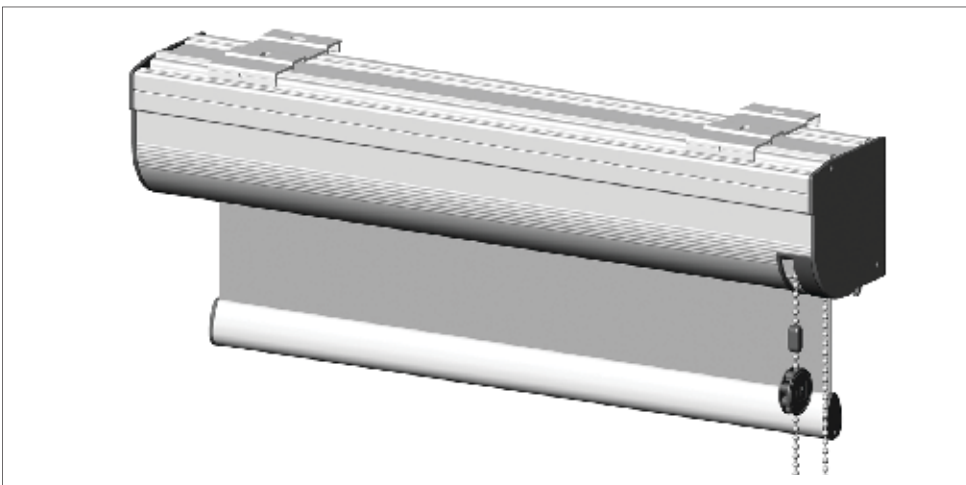

Tekno® Lite-Lift®
With Cassette 95/125

Tekno

Lite-Lift® Chain Operated Roller Systems

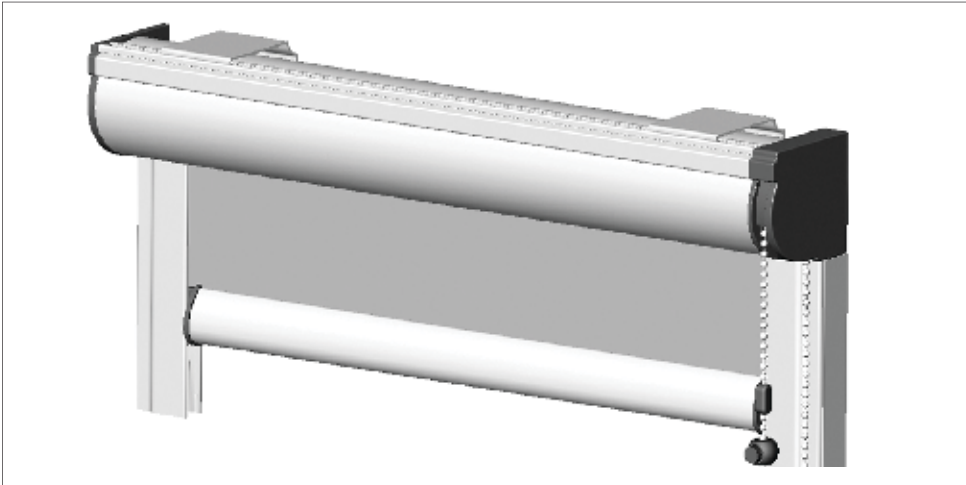

Tekno® Lite-Lift®
With Cassette 70
and Channels T-440

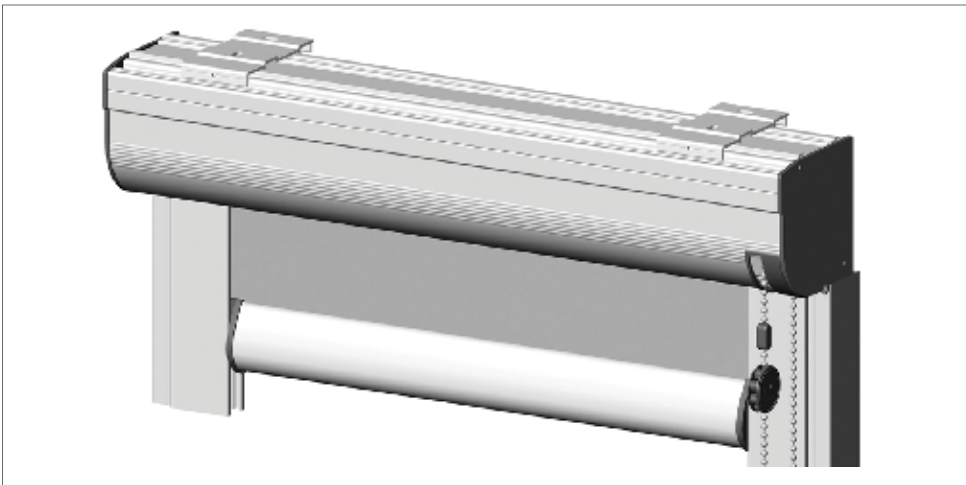

Tekno® Lite-Lift®
With Cassette 95
and Channels T-460

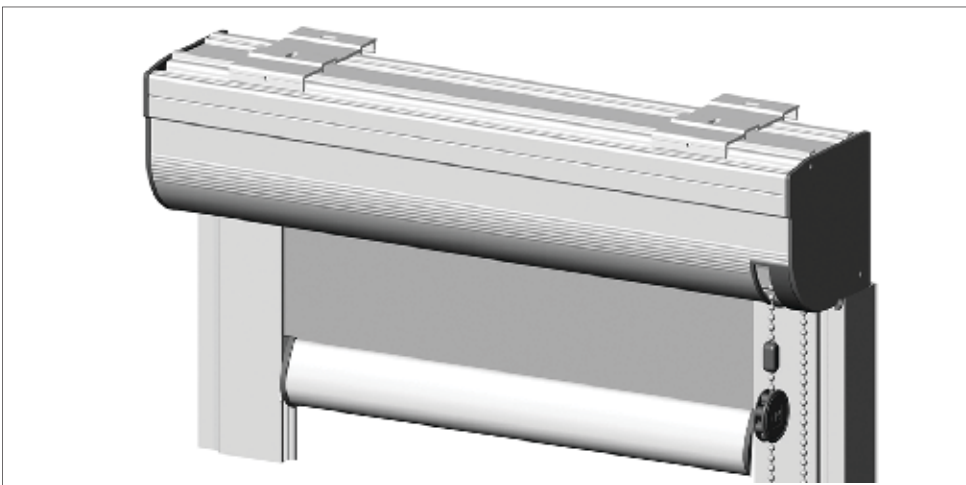

Tekno® Lite-Lift®
With Cassette 125
and Channels T-460/T-480

Tekno

Lite-Lift® Tandem Chain Operated Roller Systems

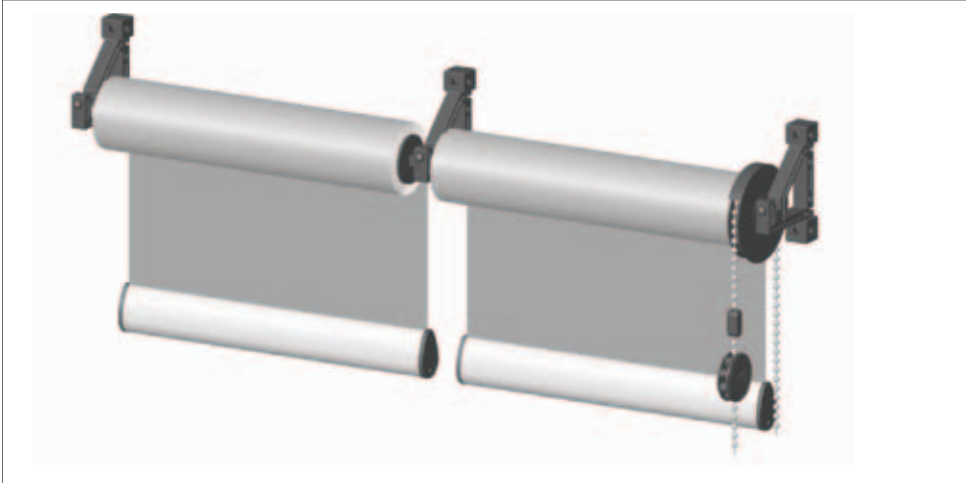

Tekno® Lite-Lift® Tandem
Open Roll TR
Shade Holder — Not Available

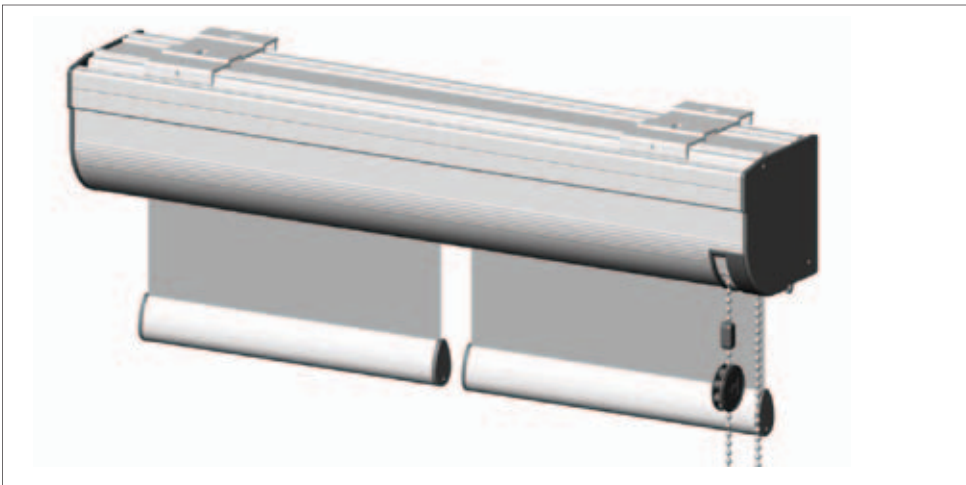

Tekno® Lite-Lift® Tandem
With Cassette 95/125

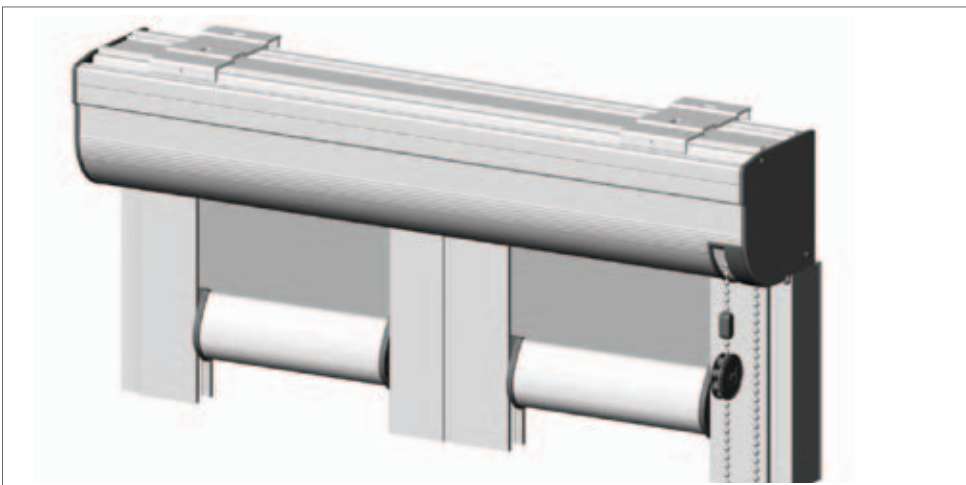

Tekno® Lite-Lift® Tandem
With Cassette 95/125
and Channels T-460

Tekno

Bracket and Cassette Details

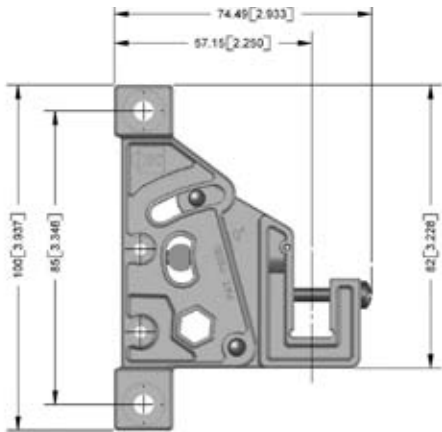

BRACKET HP

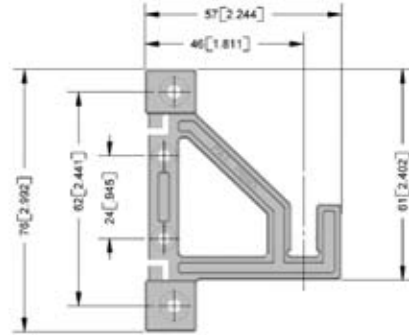

BRACKET TR

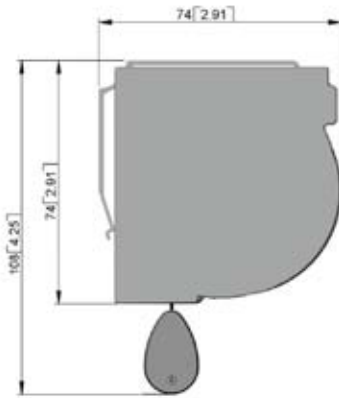

CASSETTE 70

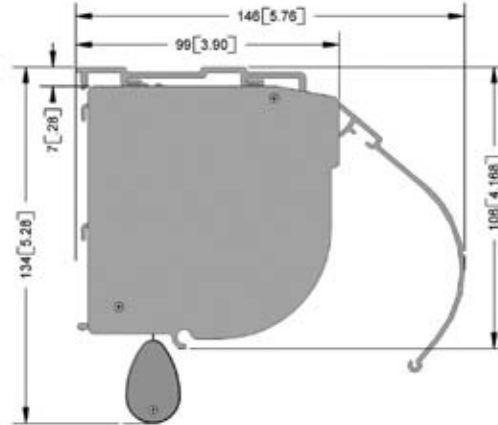

CASSETTE 95

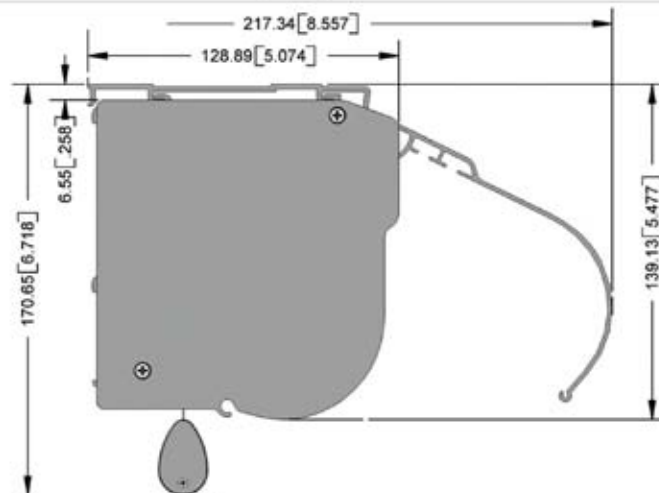

CASSETTE 125

Tekno

Lite-Lift® Tandem

Chain Operated Roller System

Side Channel Type

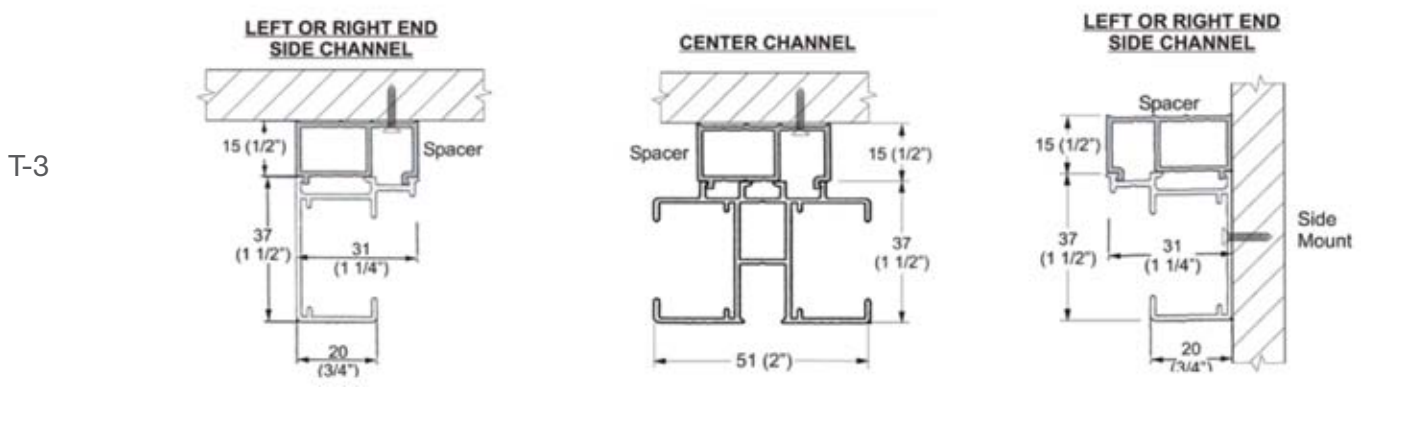
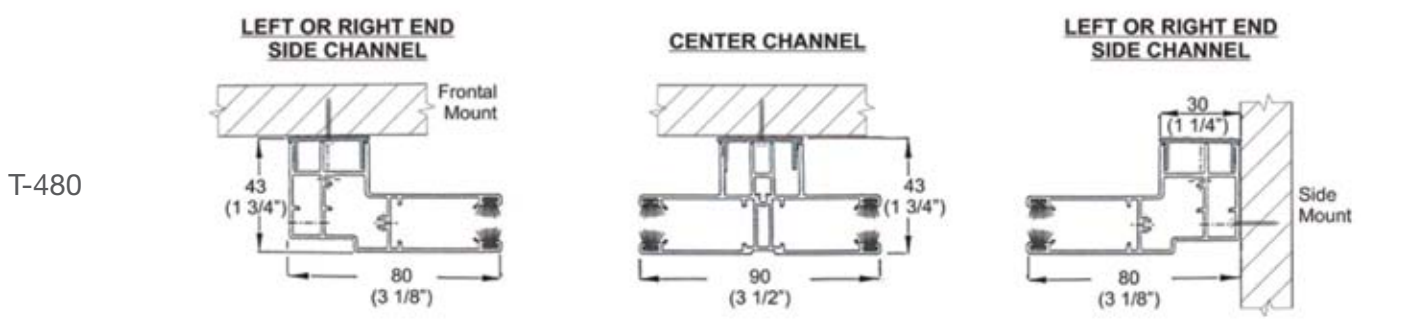
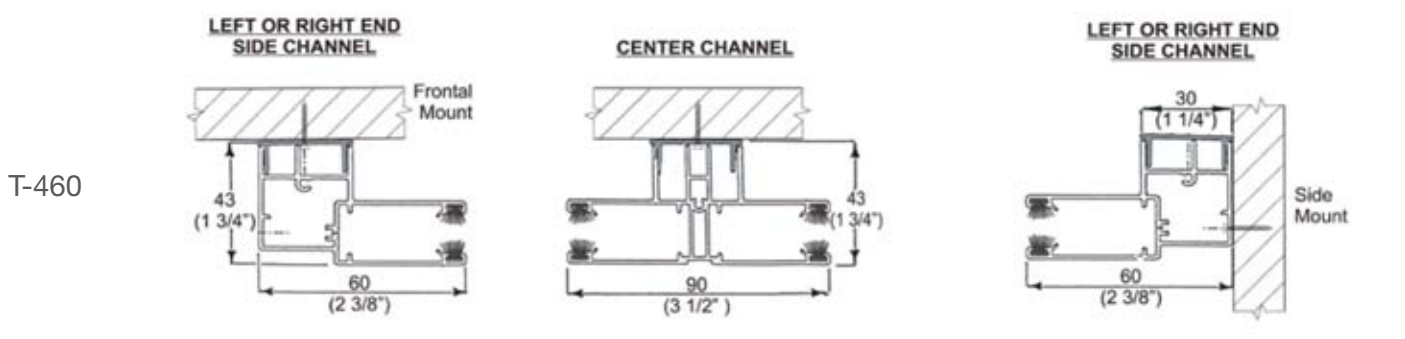

Tekno

Elektra Motorized Options

Elektra offers the following motorized options for the Tekno® Roller Systems:

Open Roll HP, Cassette 95 and 125.

- **Elektra 24V/DC** is low voltage motorized roller system.
 - Cost effective, can be easily interfaced with any centralized home automation system and sleek for small to medium sized windows
 - Available in remote control, individual and group controls, and an array of decorative switches
- **Elektra 120V/AC** is a line voltage motorized roller system for medium to large windows in available options:
 - **120V/AC** features our easy “Quick Connect” plugs allow for easy pre-wiring by electrician. Available in remote control, individual and group controls, and an array of decorative switches
 - **120V/AC RTS** plug-in unit comes with an AC Plug and can be plugged into any wall outlet
 - Eliminates problems of integration and installation specific to the wiring
 - Comprehensive range of radio control using remote controls switches, timers and integration controls are available

Tekno

Elektra 24V/DC

24V/DC Motor Operated Roller Systems

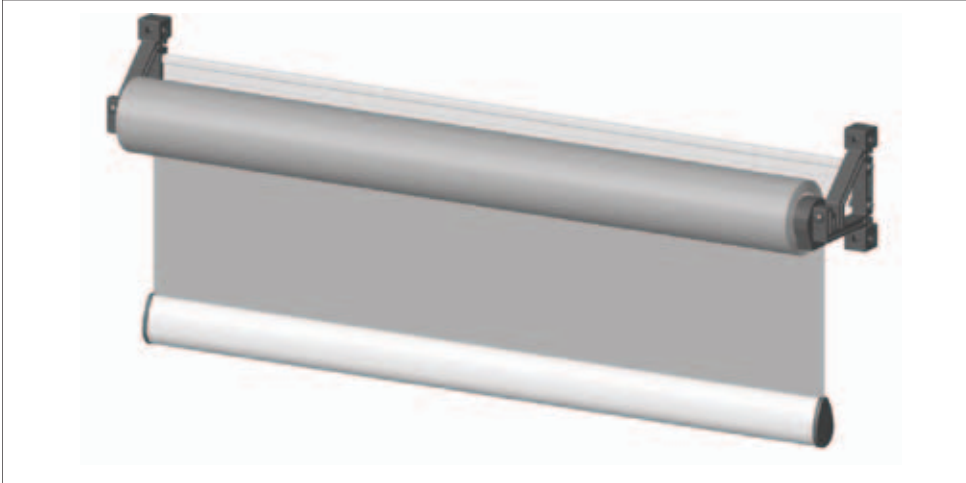

Tekno® Elektra
24V/DC
Open Roll TR
With Shade Holder

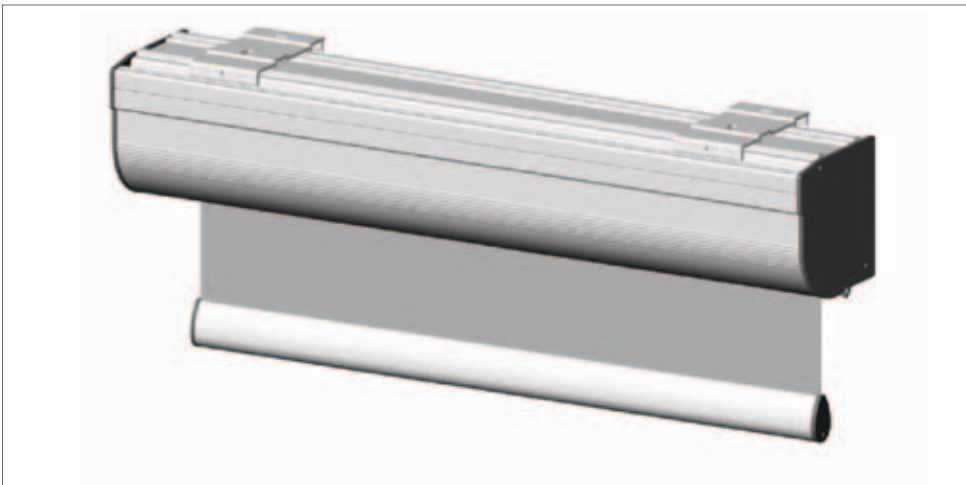

Tekno® Elektra
24V/DC
With Cassette 95

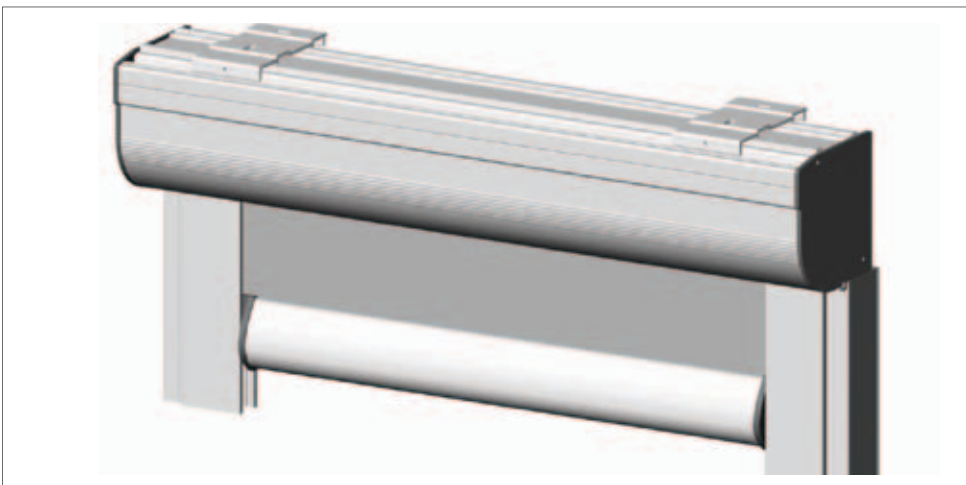

Tekno® Elektra
24V/DC
With Cassette 95
and Channels T-460

Tekno

Elektra 120V/AC

120V/AC Motor Operated Roller Systems

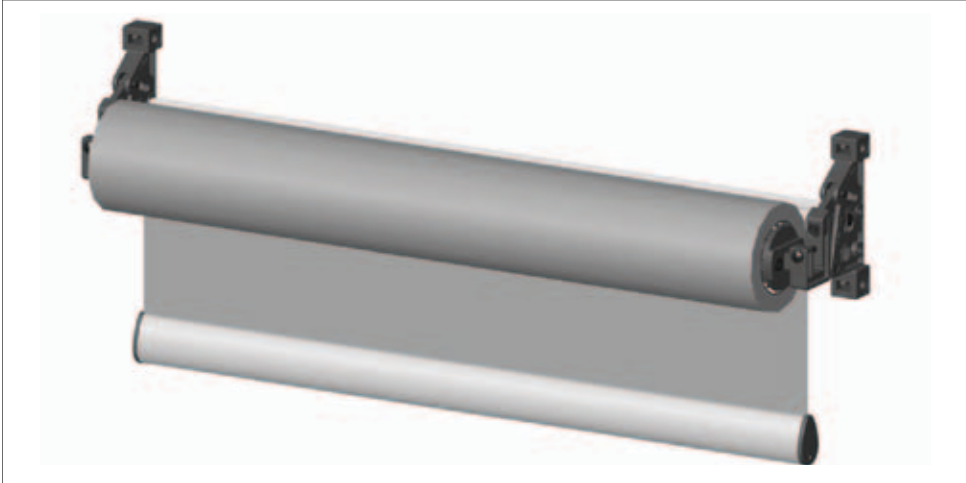

Tekno® Elektra
120V/AC
Open Roll TR
With Shade Holder
— 400, 500
— 500 RTS

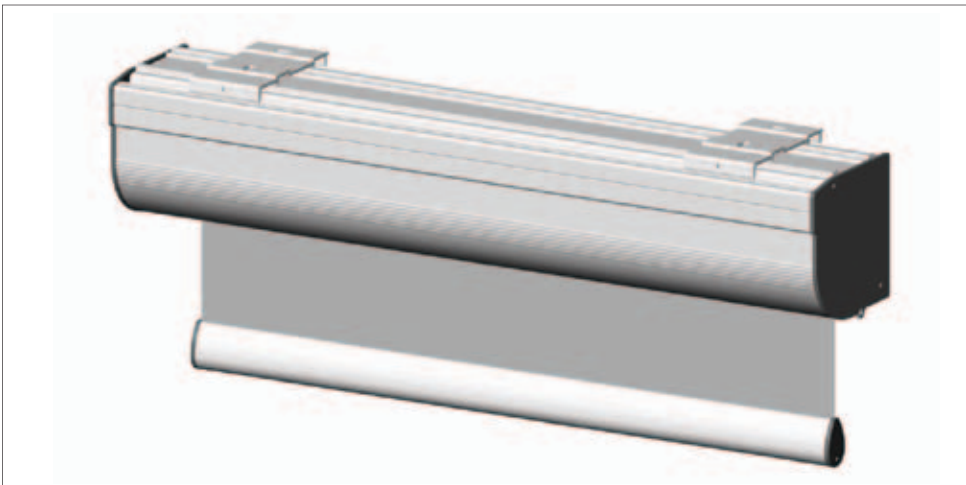

Tekno® Elektra
120V/AC
With Cassette 95/125
— 400, 500
— 500 RTS

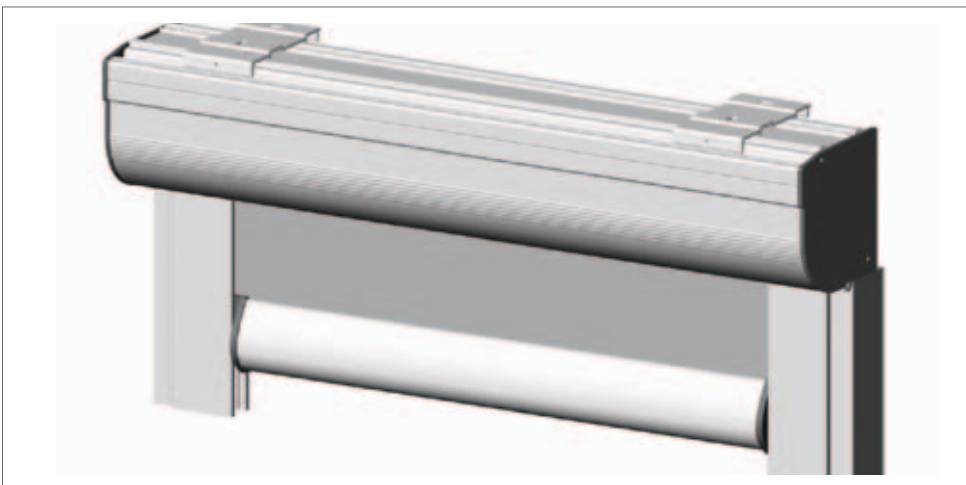

Tekno® Elektra
120V/AC
With Cassette 95/125
and Channels T-460
— 400, 500
— 500 RTS

Tekno

Elektra Tandem 120V/AC

120V/AC Motor Operated Roller Systems

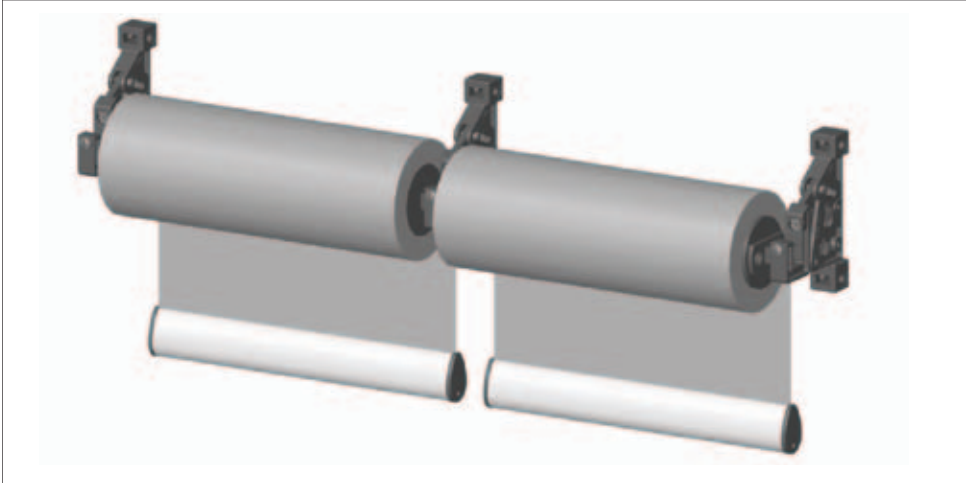

Tekno® Elektra Tandem

120V/AC

Open Roll TR

With Shade Holder – Not Available

– 400, 500

– 500 RTS

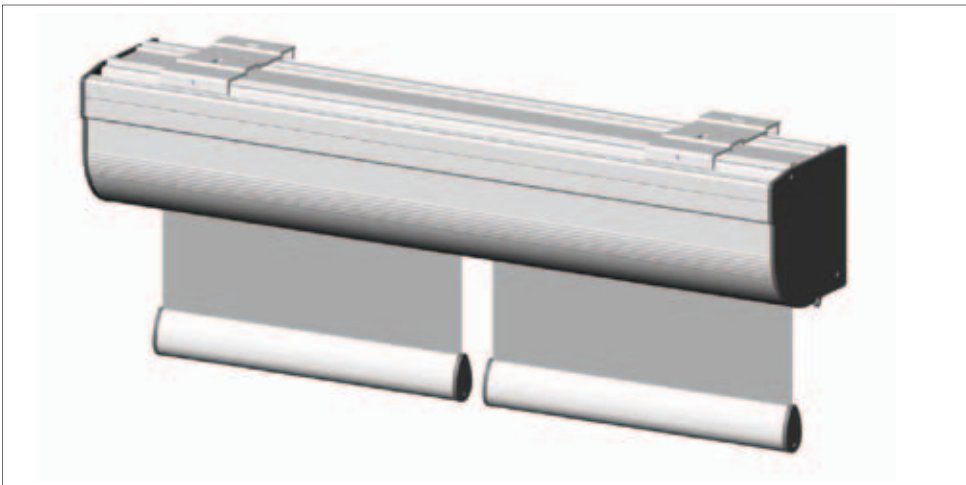

Tekno® Elektra Tandem

120V/AC

With Cassette 95/125

– 400, 500

– 500 RTS

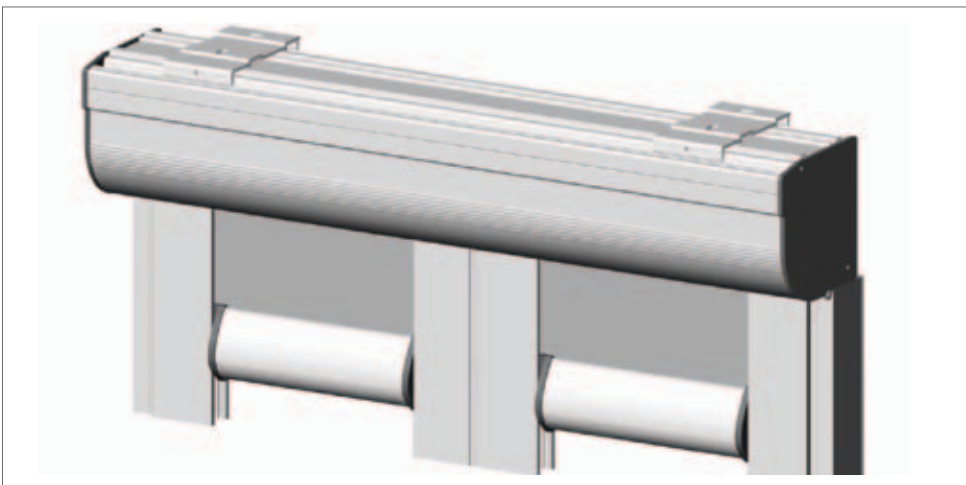

Tekno® Elektra Tandem

120V/AC

With Cassette 95/125

and Channels T-460

– 400, 500

– 500 RTS

Tekno

Elektra 120V/AC

120V/AC Motor Operated Roller Systems

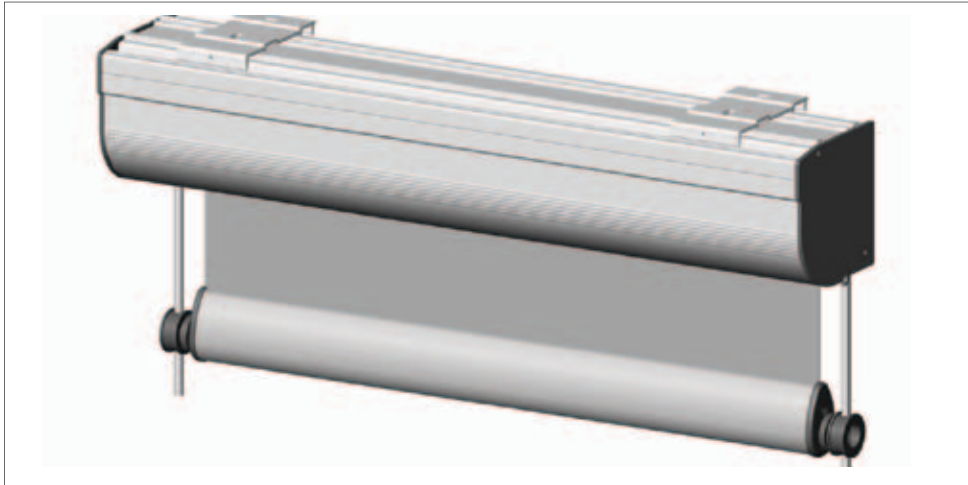

Tekno® Elektra
120V/AC
With Cassete 95/125
and Channels type 2
— 400, 500
— 500 RTS

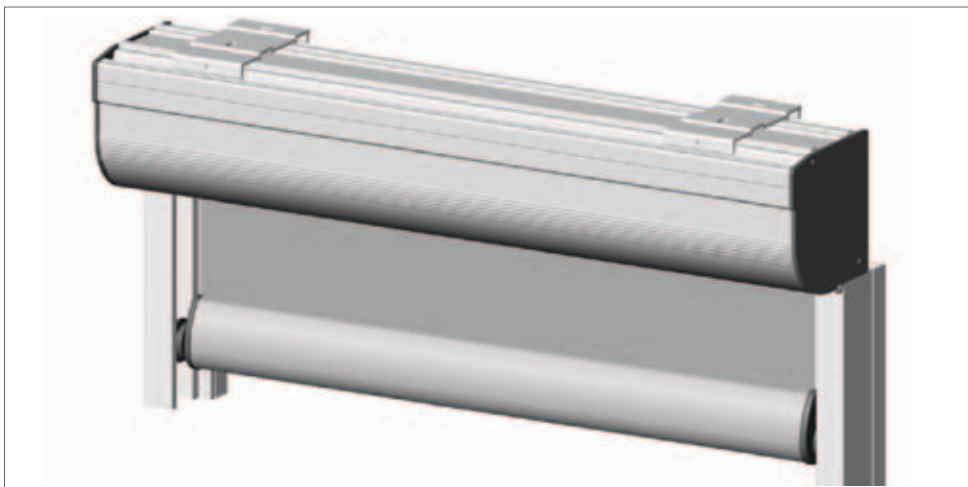

Tekno® Elektra
120V/AC
With Cassete 95/125
and Channels type 3
— 400, 500
— 500 RTS

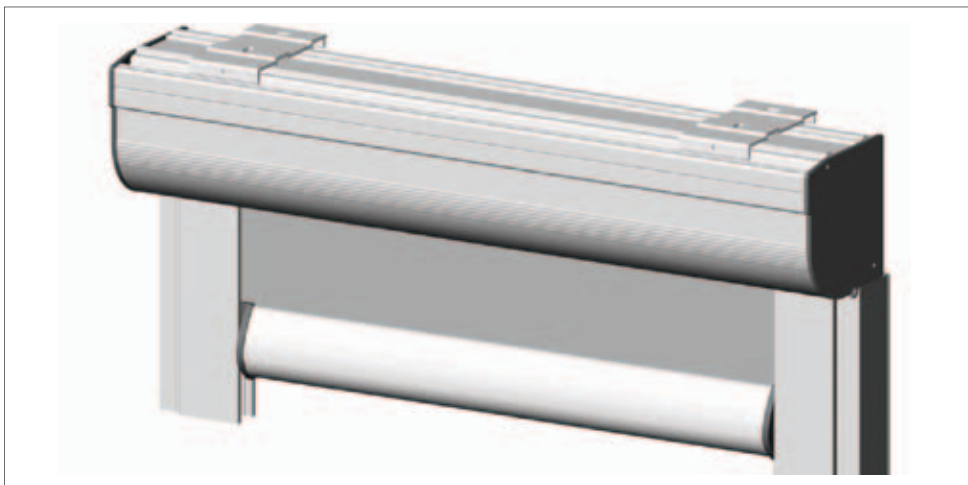

Tekno® Elektra
120V/AC
With Cassete 95/125
and Channels Type 4 T-460
— 400, 500
— 500 RTS

Tekno

Elektra Tandem 120V/AC

120V/AC Motor Operated Roller Systems

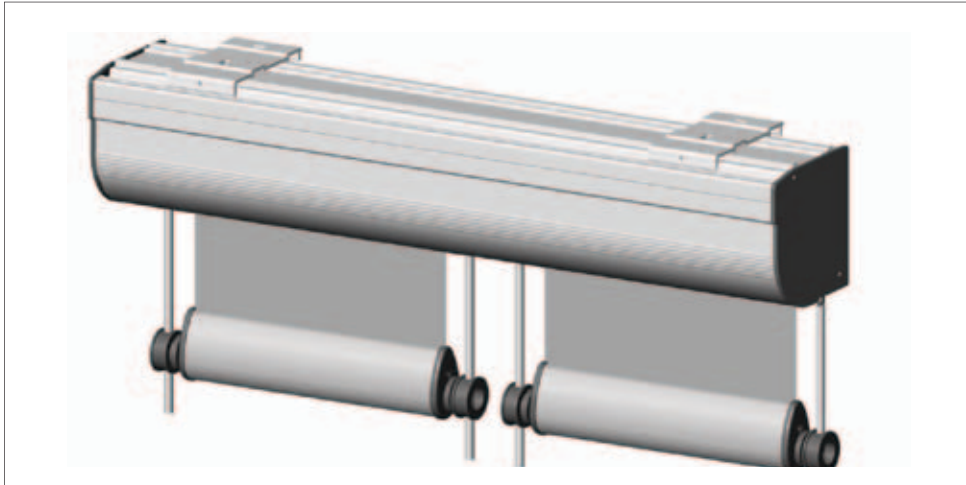

Tekno® Elektra Tandem

120V/AC

With Cassete 95/125
and Channels type 2

- 400, 500
- 500 RTS

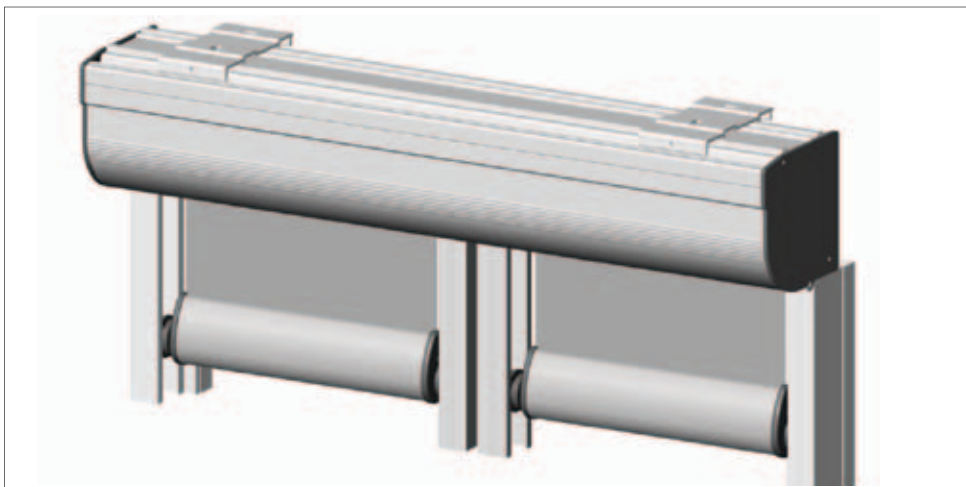

Tekno® Elektra Tandem

120V/AC

With Cassete 95/125
and Channels type 3

- 400, 500
- 500 RTS

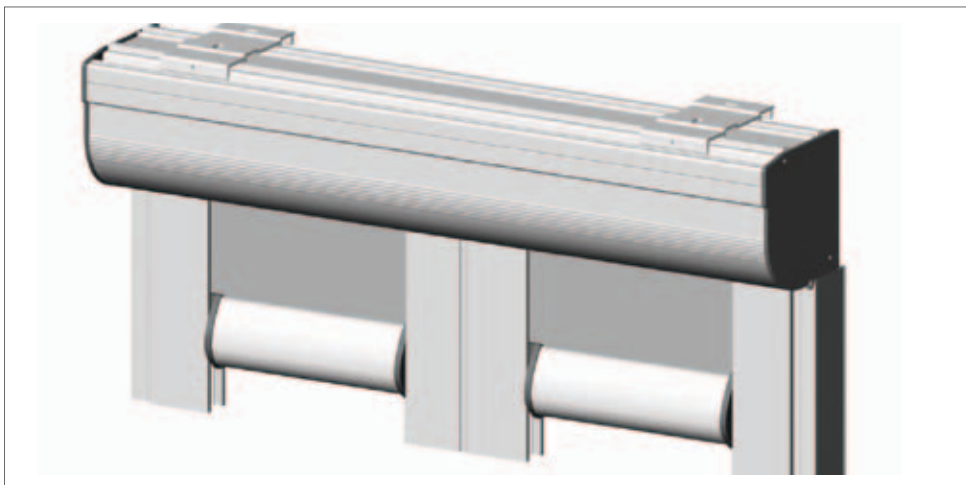

Tekno® Elektra Tandem

120V/AC

With Cassete 95/125
and Channels Type 4 T-460

- 400, 500
- 500 RTS

Tekno

Crank

Crank Operated Roller Systems

Manually crank operated roller shading systems are an alternative Lift system for large shades or in out of reach or irregular areas that typically require a motorized system.

A precision gear box drive with a 1:3 ratio offers an easy and controlled lift allowing for constant and steady rolling of the system.

A variable predetermined height 13 mm (1/2") diameter Control Shaft connected to a universal joint supports angled and irregular position of shades allowing for effective operation of the shade system.

A Detachable Control Shaft option is available for removal and storage of the Control Shaft. This prevents unauthorized use of the shade system and eliminates hazards common for physically challenged patients or simply for improved visual appearance typically with hanging chains.

A Collapsible Folding Handle allows for improved Ratio Lift of the shade system reducing strain and effort to the user.

Internal Limit Stop mechanism allows for consistent down position stop of the shade system and prevents opposite re-winding of the fabric roller assembly preventing damage to the fabric assembly.

Tekno

Crank

Crank Operated Roller Systems

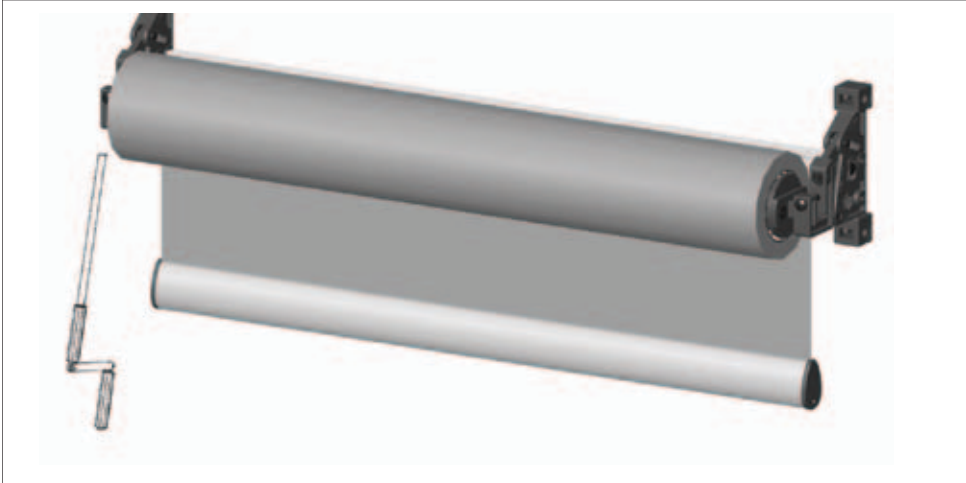

Tekno® Crank
Open roll TR
With Shade Holder

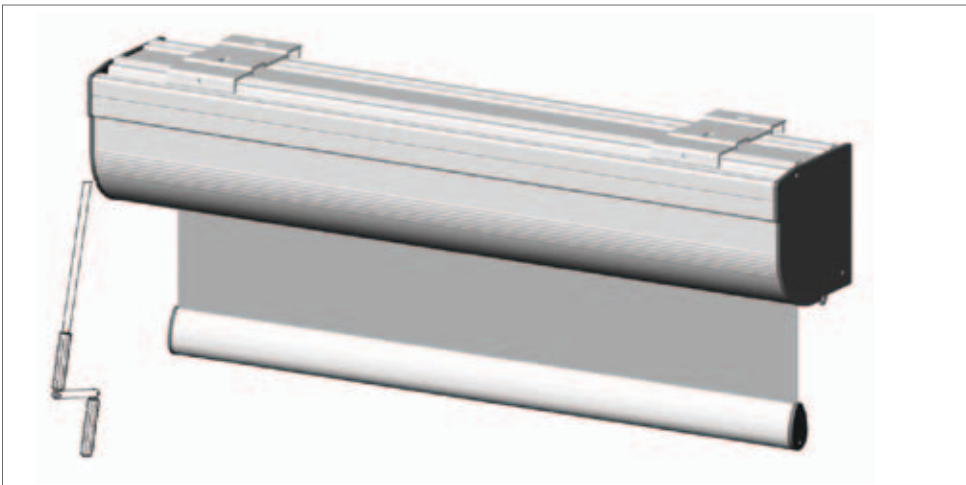

Tekno® Crank
with Cassette 125

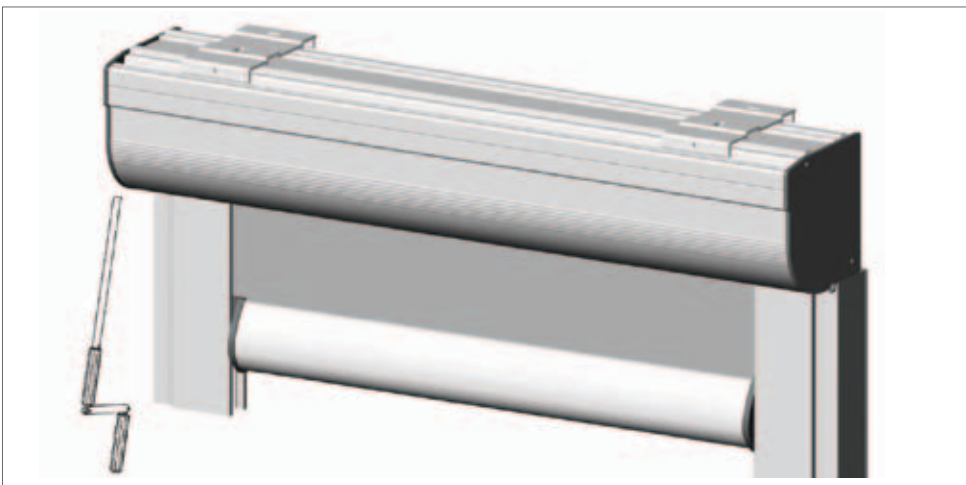

Tekno® Crank
with Cassette 125
and Channels T-460

Tekno

Crank

Crank Operated Roller Systems — Channel Options

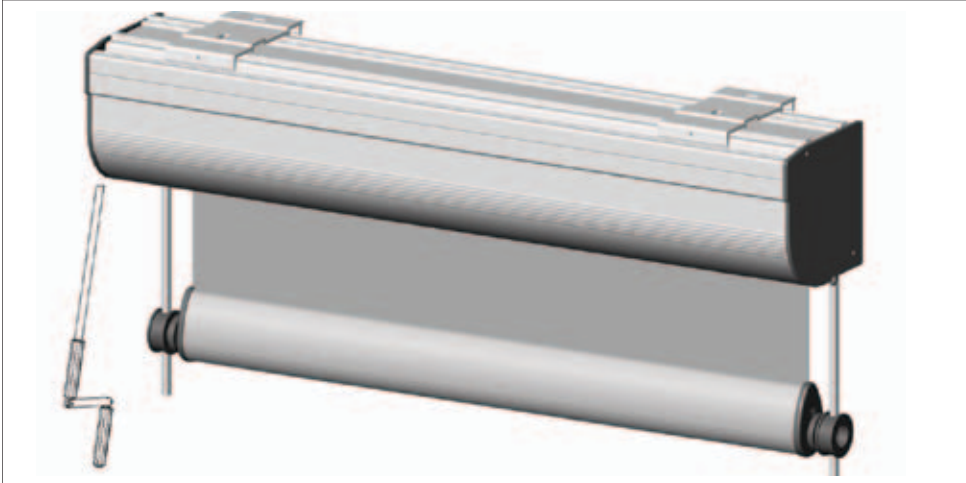

Tekno® Crank
with Cassette 125
and Channels Type 2

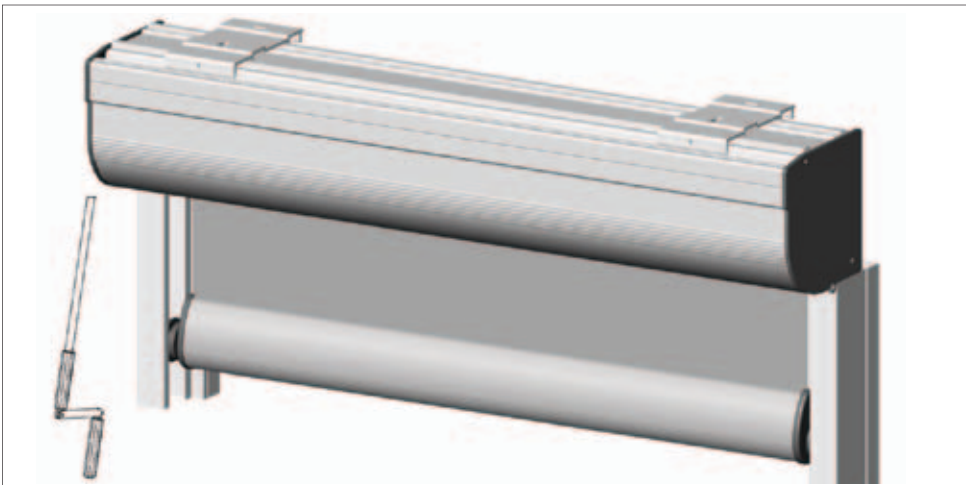

Tekno® Crank
with Cassette 125
and Channels Type 3

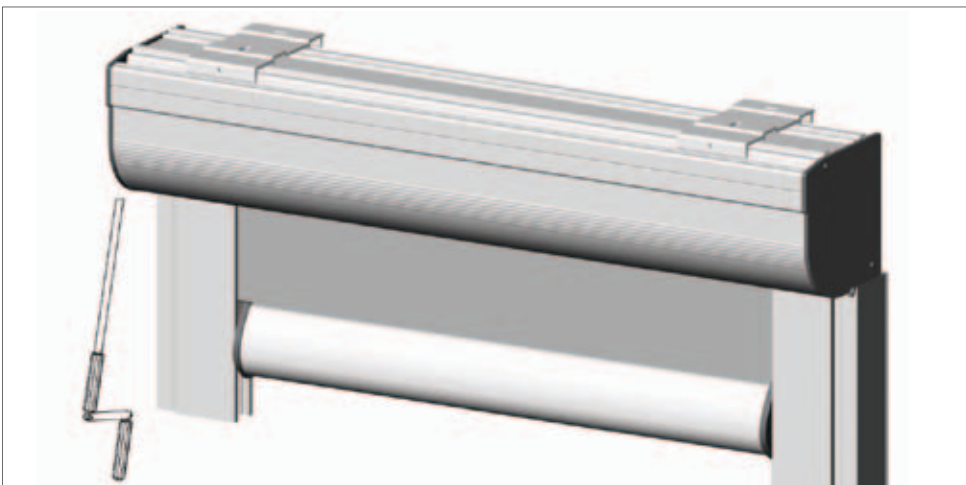

Tekno® Crank
with Cassette 125
and Channels Type 4 T-460

Tekno

Crank Tandem

Crank Operated Roller Systems — Channel Options

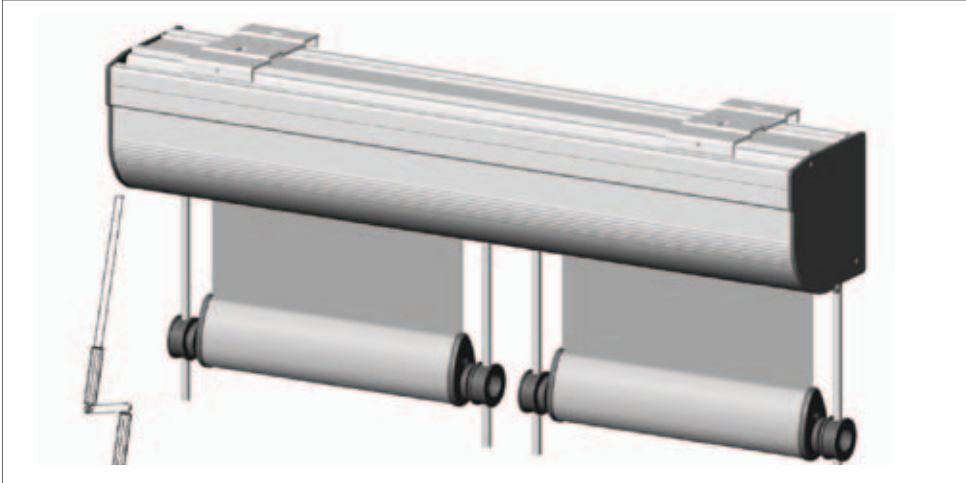

Tekno® Crank Tandem
with Cassette 125
and Channels Type 2

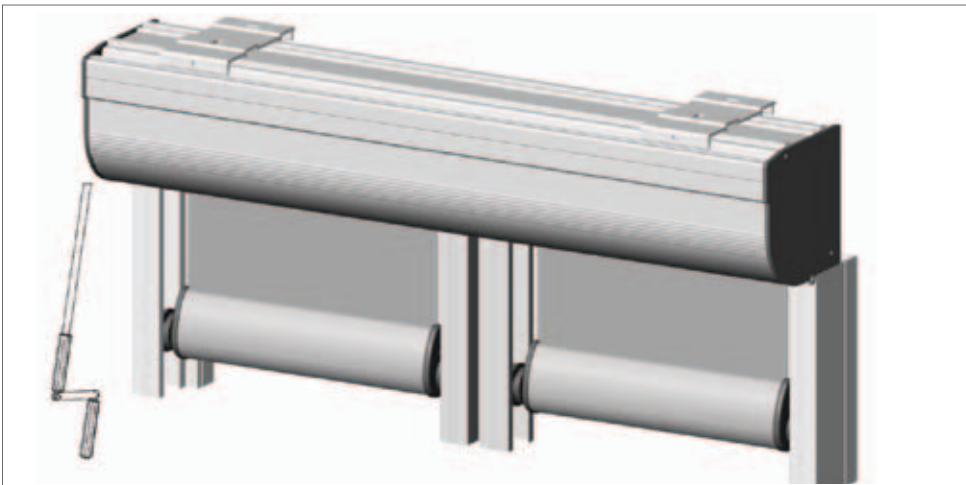

Tekno® Crank Tandem
with Cassette 125
and Channels Type 3

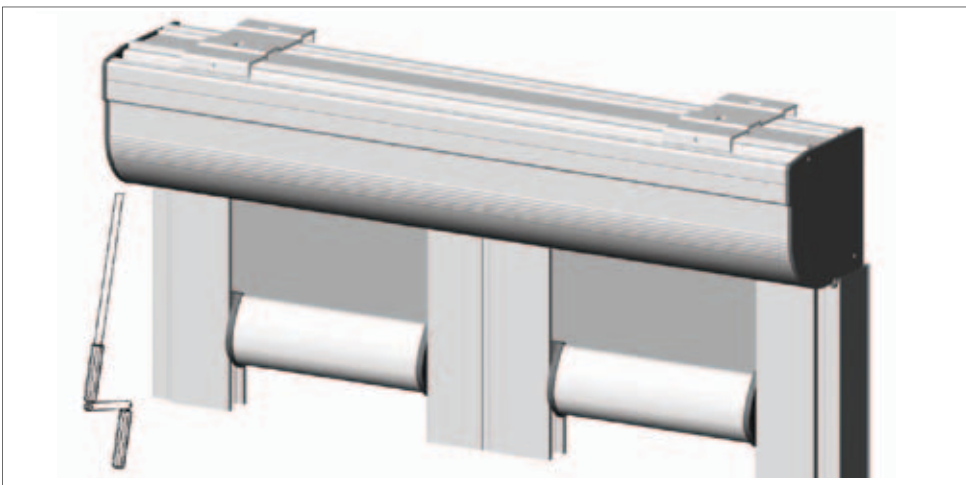

Tekno® Crank Tandem
with Cassette 125
and Channels Type 4 T-460