

VP 70/90

exterior venetian blind

SunProject™







SunProject VP 70/90 exterior venetian blinds are extremely versatile and offer a number of features and advantages:

- Optimization of lighting and shading as slats can tilt in any position based on the sun's angle
- Ideal solution in managing thermal gain and glare while providing natural daylight
- They can be retracted when shading is not required
- Optional perforated slats which allow and maintain exterior views when the blinds are fully closed
- Wide selection of slat finishes to compliment any architectural detail
- Integration of intelligent controls makes the VP 70/90 an effective solution and contributes to the development of Dynamic Façade
- Privacy protection when required
- Safety standards according to EN13659





# VP 70/90 exterior venetian blinds

## size limitations

Opening (Hop)		Stacking (Hst)		Total Product Height (H)			Dimension			
mm	in	mm	in				Single Unit		Tandem Unit	
							mm	in	mm	in
1000	39	230	9	1230	48	Min. H	800	31	800	31
1250	49	230	9	1480	58	Max. H	4250	167	4250	167
1500	59	230	9	1730	68	Min. W	550	22		
1750	69	240	9	1990	78	Max. W	4500	177		
2000	79	255	10	2255	89	Max. Area	8m <sup>2</sup>	86ft <sup>2</sup>	35m <sup>2</sup>	371ft <sup>2</sup>
2250	89	270	11	2520	99	Maximum Units	1		6	
2500	98	290	11	2790	110					
2750	108	305	12	3055	120					
3000	118	320	13	3320	131					
3250	128	340	13	3590	141					
3500	138	355	14	3855	152					
3750	148	370	15	4120	162					
4000	157	390	15	4390	173					
4250	167	405	16	4655	183					

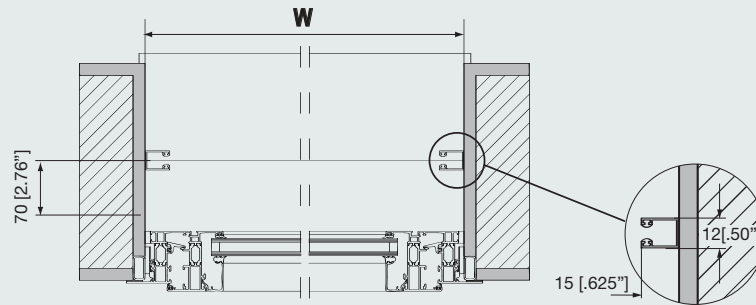

VP90 GTM (Optional Guide Cable)

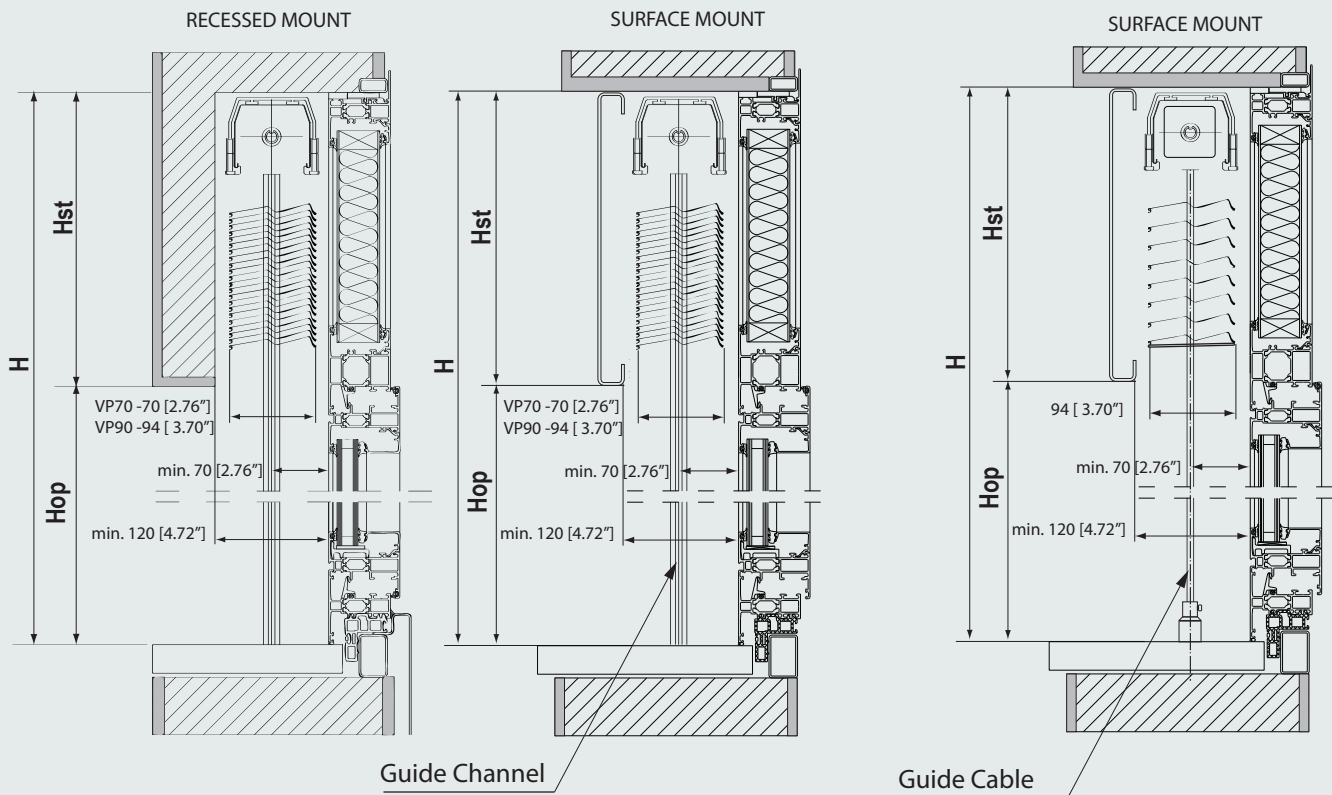

<b>H</b>	Total Height
<b>W</b>	Total Width of Opening
<b>Hop</b>	Height of Window Opening
<b>Hst</b>	Height of Stacking

CHANNEL OPTIONS

T150 SIDE GUIDING TRACKS  
(with SINGLE UNIT)

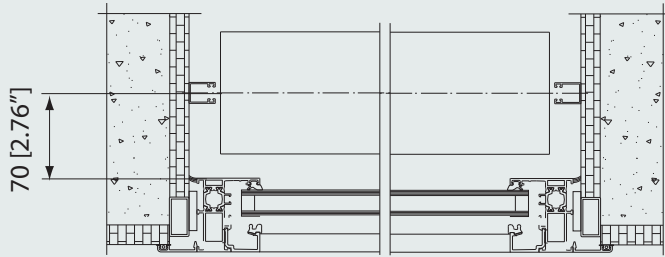

T470 INTERMEDIATE GUIDING TRACK  
(with TANDEM SYSTEM)

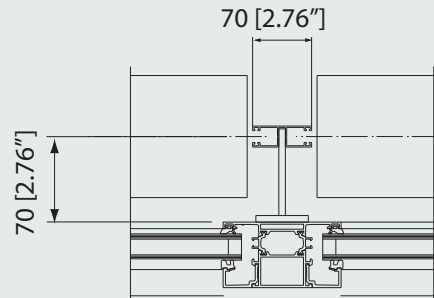

CBL-3 GUIDING CABLE  
(with SINGLE UNIT)

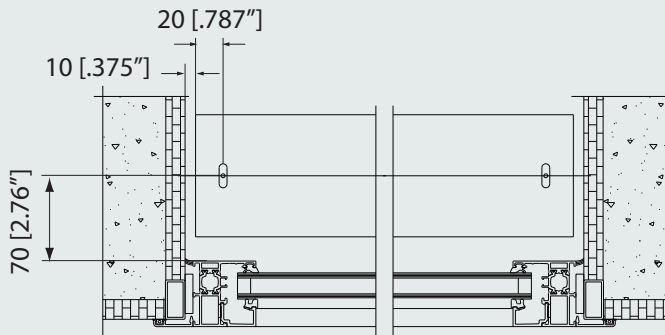

CBL-3 GUIDING CABLE  
(with TANDEM UNIT)

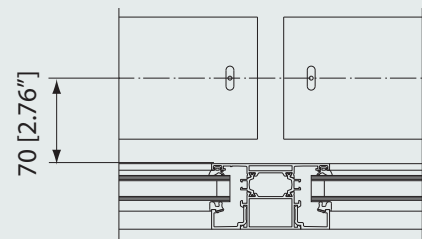

C550 SIDE GUIDING TRACKS  
(with SINGLE UNIT)

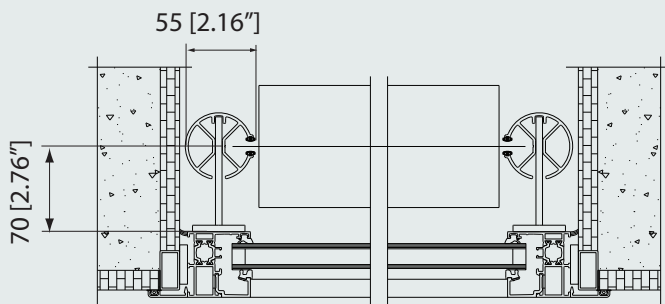

C550 INTERMEDIATE GUIDING TRACK  
(with TANDEM SYSTEM)

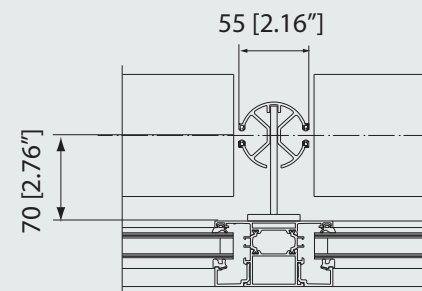

## SunProject Toro Inc.

### Head Office

205 Adesso Drive  
Concord, ON, L4K 3C4

**T:** 905.660.3117

**F:** 905.660.3365

**T:** 888.836.6980

**F:** 800.728.8636

### Western Canada Office

21331 Gordon Way, Suite 1160  
Richmond, BC, V6W 1J9

**T:** 604.980.9899

**F:** 604.980.4707

**T:** 888.980.9899

**F:** 866.980.4707

### USA

**T:** 888.836.6980

Contact: [sales@sunproject.com](mailto:sales@sunproject.com)

[www.sunproject.com](http://www.sunproject.com)

SunProject™